

PM-320

Wireless In-ear Monitor System
UHF Wireless Microphone

Simple Operation Manual

Before using the product, please read the simple operation manual and keep it in good condition.



More Products Please
Scan QR Code to follow
Us Official Website



Use WeChat Scan QR
Code to Follow us on WeChat

System Introduction

System Overview

PM-320 is a wireless monitoring system for stage performances and audio broadcasting, and a wireless listening system for large simultaneous interpretation conferences. High-fidelity sound, advanced electronic processing technology instead of the traditional complicated and heavy monitoring equipment, eliminate the howling from the monitoring equipment, and make the performance reliable and perfect.

System performance characteristics

- Metal 1/2 EIA standard 1U case.
- The housing of PM-320R receiver is made of light-weight and tough alloy materials.
- Exquisite and simple OLED display.
- The receiver uses the UHF frequency band, and the CPU controls diversity reception to reduce dead spots and ensure stable reception.
- The bandwidth is 32MHz and there are 1280 adjustable frequencies. 1-10 Channel groups, more than 180 fixed frequencies to choose. Channel groups U1-U5 can set and save frequencies freely.
- Stereo and mono selection.
- Treble boost function, limit control function.
- The stable PLL phase-locked oscillation circuit, combined with the “noise lock” squelch can effectively block stray RF.
- With headphone monitoring output.
- With long transmission distance, it is suitable for various occasions.

Packing list

PM-320:

- ◆ Receiver *1
- ◆ Transmitter *1
- ◆ BNC antenna *1
- ◆ External power adapter*1
- ◆ 1.5VAA battery*2
- ◆ Stereo line*2
- ◆ 1U Rack mount kit (including screws) *1 set
- ◆ Simple operation manual *1

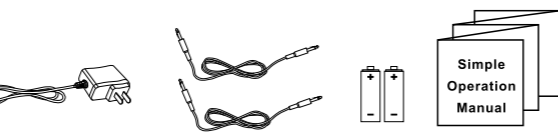
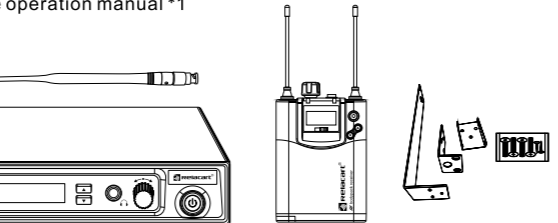

Transmitter function introduction

Front panel:

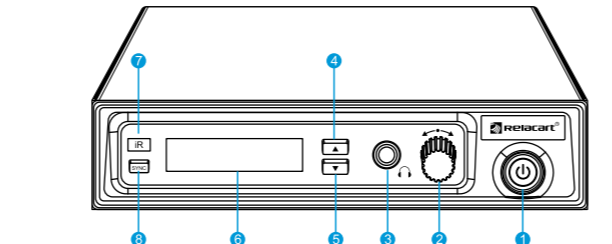

- 1 Power switch (with indicator light) .
- 2 Function operation knob: turn this knob left and right to select the menu, press the knob to set the system operation menu.
- 3 Headphone monitor jack, stereo output.
- 4 “▲” Volume operation button: increase the input volume gain.
- 5 “▼” Volume operation button: attenuate the input volume gain.
- 6 OLED display: display frequency, frequency group and channel, battery life, etc.
- 7 Infrared data transmission (iR) window: Infrared pairing window, receiving the data signal transmitted by the receiver.
- 8 Infrared data transmission data (SYNC) button: Press this button to transmit the channel and setting data of the transmitter to the receiver.

Rear panel:

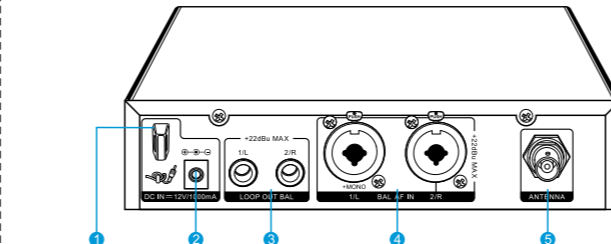

- 1 Anti-pull device, used for power cord.
- 2 The 12V connection jack (DC IN) of the external power adapter.
- 3 A: 6.3 mm jack, the left side is the audio output (LOOP OUT BAL 1/L) .
B: 6.3 mm jack, the right side is the audio output (LOOP OUT BAL 2/R) .
- 4 A: XLR-3/6.3 mm combo jack, on the left is the audio input (BAL AF IN 1/L) .
B: XLR-3/6.3 mm combo jack, on the right is the audio input (BAL AF IN 2/R) .
Note: In mono mode, the signal from the left audio input terminal (XLR-3/6.3 mm combo jack, BAL AF IN 1/L) will be sent.
- 5 BNC interface, antenna output interface.

Transmitter display overview

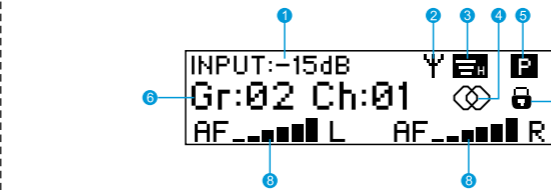

- 1 Volume input: Display the set volume input parameters.
- 2 Radio frequency display: The device is transmitting radio signals.
- 3 Transmit power: set transmit power. (“”) High transmit power, (“”) low transmit power)
- 4 Audio mode: When mono is selected, it is displayed as “”, Pilot function is automatically turned off.
When stereo is selected, it is displayed as “”, Pilot function is automatically turned on.
- 5 Control sound “P” : Control sound analysis has been enabled. When stereo is selected, the pilot analysis sound is turned on automatically, and when mono is selected, the pilot analysis sound is turned off automatically.
- 6 “Display Mode” status display: A. Frequency: the set transmitting frequency.
B. Group, channel: set group and channel.
C. Name: set name freely.
- 7 Key lock: The key lock is enabled on the transmitter.
- 8 Audio frequency: left (AF L) and right (AF R) audio channels, indicating the level of audio input.

Receiver Function Introduction

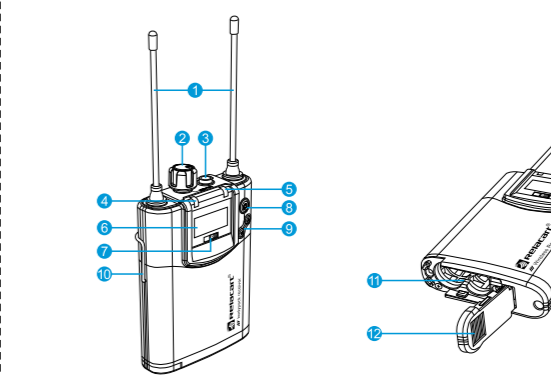



- 1 Antennas A and B.
- 2 Power switch/volume potentiometer.
- 3 3.5mm stereo headphone monitor jack.
- 4 Antenna A indicator: When the battery level shows 1 bar, the antenna indicator changes from blue to red.
- 5 Antenna B indicator: When the battery level shows 1 ba, the antenna indicator changes from blue to red.
- 6 OLED display: display frequency, frequency group channel, battery life, etc.

- 7 Infrared data transmission window (iR) : Infrared frequency window, which transmits the channel data of the receiver to the transmitter, so that the frequency of the transmitter and the receiver are consistent.
- 8 SET key: enter the menu/or confirm the menu settings.
- 9 “▲ / ▼” : select function operation keys.
- 10 Belt clip: fix the receiver around the waist of the user.
- 11 Battery compartment: fill 2 AA batteries. (It is best to use alkaline 1.5V AA batteries. Please replace two batteries at the same time when replacing new batteries.)
Warning: Do not install the battery with wrong polarity, which may damage the internal electronic parts.
- 12 Battery cover lock switch: Push this switch to open the battery cover.

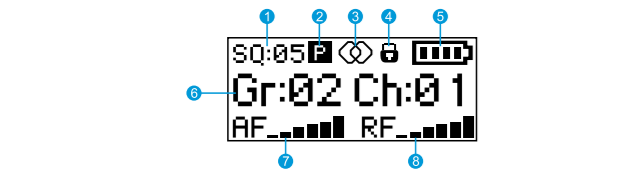
Receiver display overview



- 1 Squelch Threshold: Displays the set squelch threshold parameters.
- 2 Pilot control tone.
- 3 Audio mode: When mono is selected, it is displayed as “”, Pilot function is automatically turned off. When stereo is selected, it is displayed as “”, Pilot function is automatically turned on.
- 4 Key lock: Key lock is enabled on the receiver.
- 5 Battery status: 4 bars are fully charged, please replace with new ones in time when there is one bar left.
- 6 “Display Mode” status display: A. Frequency: the set transmitting frequency. B. Group, channel: set group and channel. C. Name: freely set name.
- 7 “AF” audio frequency: indicates the audio input level of the transmitter.
- 8 “RF” radio signal level: the strength of the received radio signal.

Menu

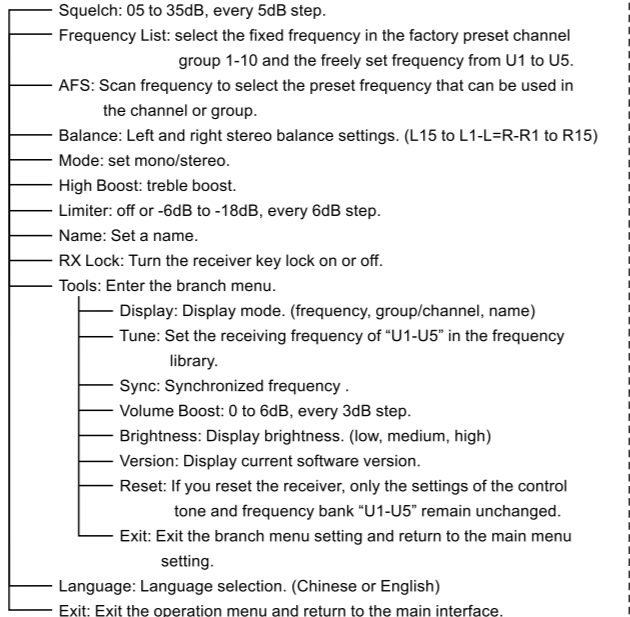
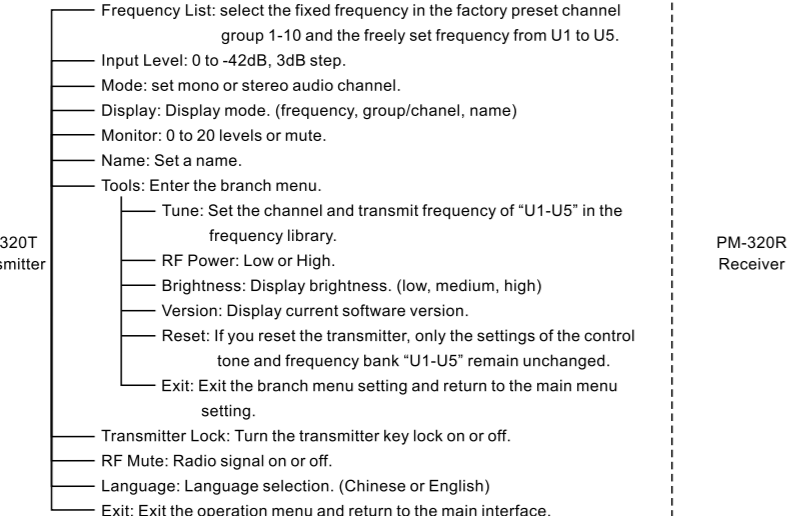

System installation and connection

System installation

1. In order to achieve the best operation of the equipment, the height of the receiver should be higher than 1 meter from the bottom and at least 1 meter from the wall surface.
2. Keep the antenna away from interference sources, such as computer equipment, digital equipment, televisions and cars, and also away from large-area metal objects.
3. Install the antenna on the antenna connector on the rear panel, and pull the antenna to a position at a 45° angle to the vertical.
4. Minimize obstacles as much as possible between the location of the receiver and the place where the transmitter is used.
5. When two transmitters are used at the same time, the distance between the transmitter and the receiver must be at least 2 meters.

System connection

1. Connect the output end of the DC 12V/1000mA DC output power supply to the transmitter DC power input socket. To prevent the DC plug from accidentally detaching, first pass the wire through the fixing hole and then tighten it.
- (Note: The input voltage of the AC power adapter must be selected to meet the power supply specification range of the area of use.)
2. There are two types of audio jacks on the rear panel of the transmitter, namely Φ 6.3mm balanced output socket and XLR-3/6.3 mm combined balanced input jack.
 - ① Use a suitable cable to connect the output of an external device (such as a mixer or a second PM-320TX) to the XLR-3/6.3 mm combined balanced input jack.
 - ② Use a suitable cable to connect the input end of an external device (such as a mixer or a second PM-320TX) to the Φ 6.3 mm balanced output jack.

System connection

- (Note: After the signals of the input jacks BAL AF IN 1/L and BAL AF IN 2/R are separated, they continue to be transmitted to the output jacks LOOP OUT BAL 1/L and LOOP OUT BAL 2/R. Therefore, you can only transmit Use the output jack when the machine is switched on.)
3. Set the appropriate audio input level
The intensity of the audio input signal will be displayed on the AF level meter on the OLED display panel, and the intensity of the input audio signal will be adjusted appropriately. Therefore, the input intensity must be adjusted appropriately to obtain the best signal-to-noise ratio and dynamic range, and to avoid signal distortion.
 4. Headphone connection
Insert the monitor headphone connection plug into the 3.5mm headphone stereo socket, you can also connect general headphones or connect the output end to the audio input of other audio equipment.
Note: The headphone output socket is a stereo output. Note that the connected plug must be a stereo plug. If it is a mono headphone plug, one side of the output may be short-circuited and the headphone output circuit on the other side may be burned.
 5. Multi-system mixed group connection mode
Some performers need to hear the signal of their own playing instrument and the mixed instrument. With the help of this device, each performer can hear this “combination” effect or their independent performance effect, and send a whole band from the mixer Mix the effect to the first transmitter (PM-320T) BAL AF IN 1/L and BAL AF IN 2/R input terminals, and then from the LOOP OUT BAL 1/L and LOOP OUT BAL 2/R output terminals, connect To the BAL AF IN 1/L and BAL AF IN 2/R inputs of a transmitter. Using this link, you can operate all transmitters, and create a mixer to listen to each performer through the auxiliary output of the mixer. Send these different combinations to each performer’s receiver (PM-320R).

System equipment connection diagram

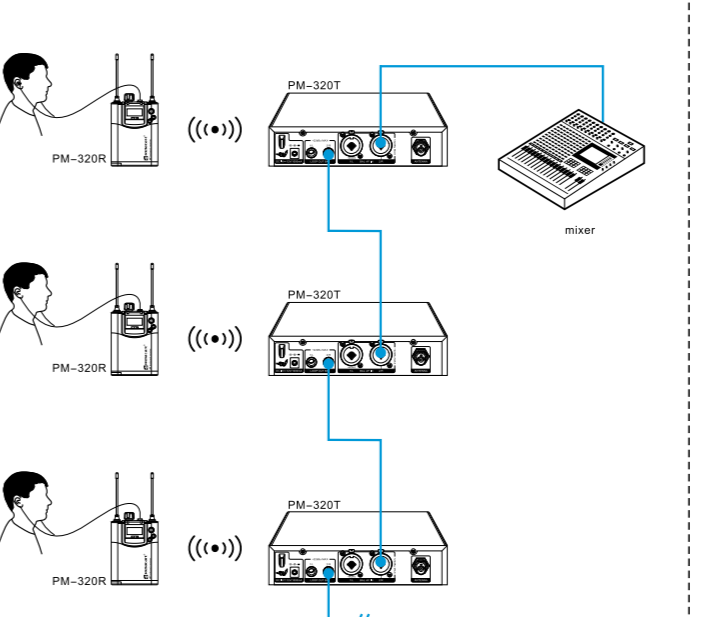

Specification

PM-320R Stereo Mini Receiver

Receiving method	antenna diversity reception
Carrier frequency band	554MHz~936 MHz
Maximum deviation	±48KHz
Number of channel groups	single channel
Modulation method	FM MPX (stereo)
S/N ratio	>100dB
T.H.D.	<0.9%@1KHz
Stereo separation	≥55dB, at 1KHz
Frequency response	25Hz-15KHz ±3dB
Battery	AAx2
Current consumption	165mA (typical)
Battery life	> 8 hours
High frequency boost	+8 dB at 10KHz
Limiter	each step can be adjusted 6dB, can be turned off
Frequency stability	±0.005% (0~50°C)
Oscillation mode	PLL phase lock frequency synthesis
Working distance	100 meters in general (open area)
Output socket	φ 3.5mm stereo headphone socket
Output power	2x150mW at 1KHz (T.H.D.: 3%)
Sensitivity	When the offset is equal to 25KHz, 6dBuV, S/N>60dB
Frequency bandwidth	32MHz (1280 transmitting frequencies, tunable in units of 25 KHz)
Dimensions	90mm (height) x 65mm (width) x 23mm (depth)
Weight	about 100g

PM-320T Stereo Transmitter

Main Frame Size	1 / 2 EIA standard 1U
Frequency band	554MHz~936 MHz
Maximum deviation	±50KHz
Number of channel groups	single channel
Modulation method	FM MPX (stereo)
S/N ratio	>100dB
T.H.D.	<0.9%@1KHz
Frequency bandwidth	32MHz
Comprehensive frequency response	25Hz-15KHz ±3dB
Output power	30mW-50mW
Current consumption	140mA (typical)
Power supply mode	DC 12V
Frequency stability	±0.005% (-10~50°C)
Oscillation mode	PLL phase lock frequency synthesis
Harmonic radiation	more than 60dB lower than the main wave
Audio output	φ6.3mm balanced socket x2
MPX control tone	frequency: 19KHz, deviation: ±5KHz
Audio input	Line level x 2, XLR and φ6.3mm co composite socket
Dimensions	206mm (width) x 44mm (height) x 199mm (depth)
Weight	about 955g